

# SPECTRO Series

## ► SPECTRO-3-30-UV

- Measuring range typ. 15 mm ... 80 mm
- Ideal adjustment to luminescent objects
- Up to 31 colors can be stored
- RS232 interface (USB or Ethernet adapter is available)
- 9x UV LED, 375 nm, focused (AC-/DC-/PULSE-operation or OFF for luminous objects can be switched)
- Detection of different luminescent colors
- Insensitive to outside light (in AC- or PULSE-operation)
- Brightness correction can be activated (STAT/DYN)
- Scan frequency max. 35 kHz (in DC- or OFF-operation)
- Switching frequency typ. 60 kHz
- Several TEACH functions (via PC, PLC, or push button)
- Various evaluation algorithms can be activated
- "BEST HIT" mode ("human color assessment")
- Switching state display by means of 5 yellow LEDs
- Parameterizable via Windows® software, scope function
- Temperature compensated
- Averaging can be activated (from 1 up to over 32000 values)
- 3-color filter detector (true color detector: "human color perception")

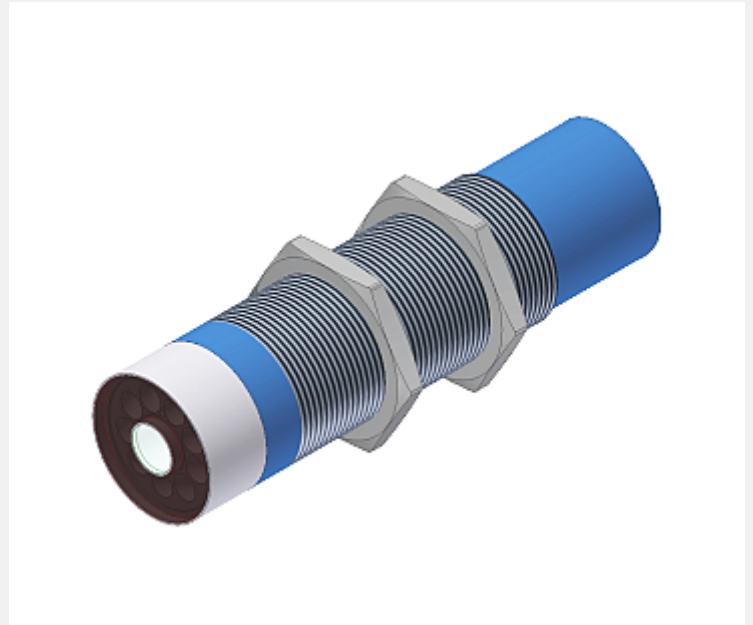

## Design

### Product name:

**SPECTRO-3-30-UV**  
**SPECTRO-3-30-UV-10x1**  
 (incl. Windows® PC software SPECTRO3-Scope)

### Accessories: (p. 9-10)

**FL-34** (flange)  
**WFL-34** (flange, angle type)  
**SPECTRO-3-30-OFL**  
 (offline top part/spacer)

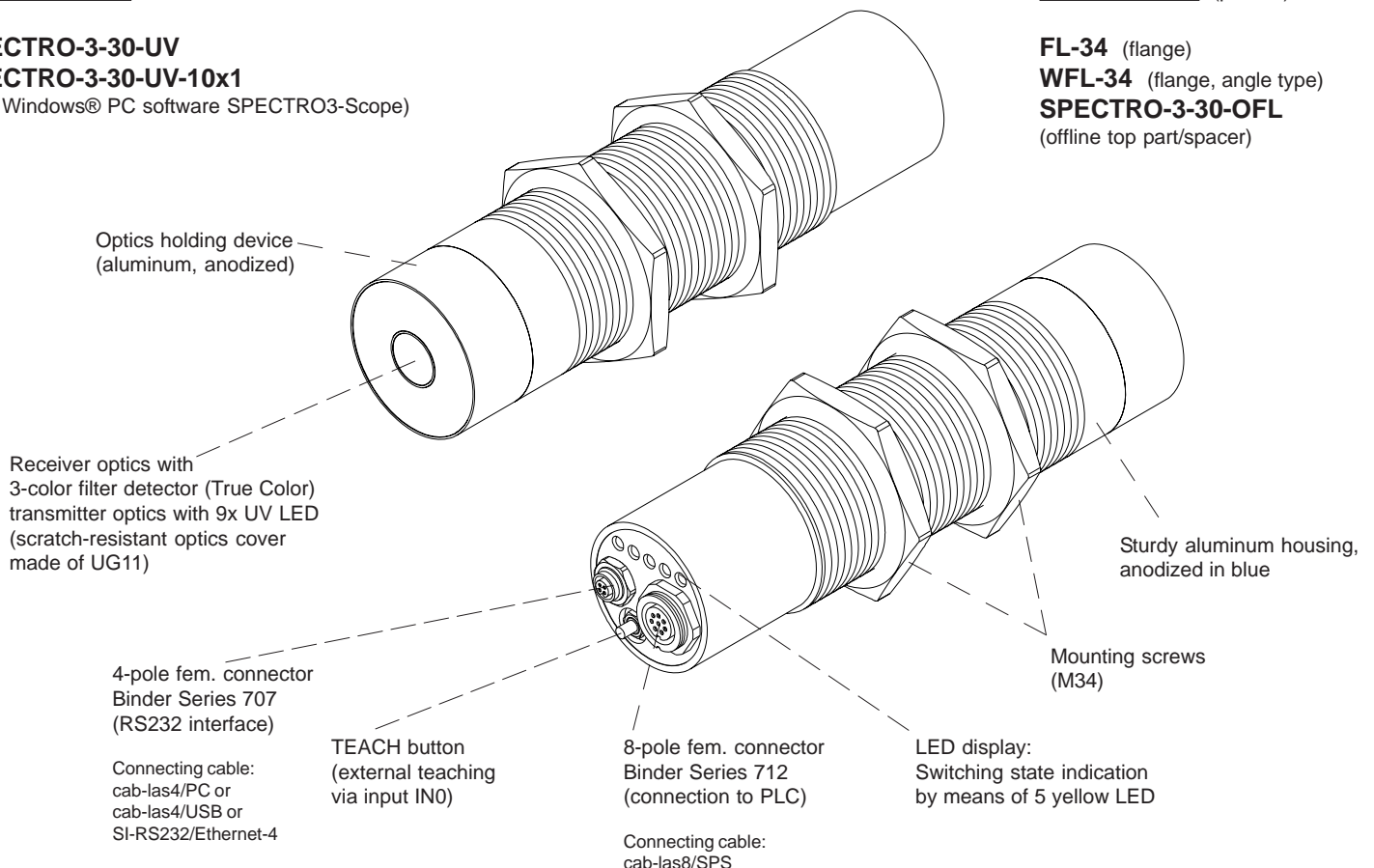



**Technical Data**

Model	SPECTRO-3-30-UV	SPECTRO-3-30-UV-9x1
Voltage supply	+24VDC (± 10%), reverse polarity protected, overcurrent protected	
Current consumption	< 220 mA	
Max. switching current	100 mA, short circuit proof	
Switching state indication	5 yellow LED visualize the physical state of the outputs OUT0 ... OUT4	
Input digital (1x)	IN0 (Pin 3), digital (0V/+24V) or teach button at the housing	
Outputs digital (5x)	OUT0 ... OUT4 (Pin 4 ... 8): digital (0V/+24V), npn-/pnp-able (bright-/dark-switching, can be switched)	
Interface	RS232	
Pulse lengthening	0 ... 100 ms, adjustable via PC software	
Averaging	max. 32768 values, adjustable via PC software	
Scan frequency	LED operation, can be switched via PC software: AC operation: max. 20 kHz (depends on parameterization) DC and OFF operation: max. 35 kHz (depends on parameterization) PULSE operation: max. 5 kHz (depends on parameterization)	
Switching frequency	typ. 60 kHz	
Transmitter (light source)	9x UV LED, 375 nm, focused	
Transmitter control	can be switched via PC software: AC operation (LED MODE-AC), DC operation (LED MODE-DC), OFF operation (LED MODE-OFF)	
Measuring range	typ. 15 mm ... 80 mm	
Receiver	3-color filter detector (TRUE COLOR detector, "human color perception"), color filter curves acc. to CIE 1931	
Receiver gain setting	8 steps (AMP1 ... AMP8), adjustable via PC software	
Ambient light	max. 5000 Lux	
Detection range (half intensity width)	typ. 10 mm at a distance of 15 mm typ. 15.5 mm at a distance of 30 mm typ. 20 mm at a distance of 40 mm	to be added
Reproducibility	in the X, Y color range each 1 digit at 12-bit A/D conversion	
Temperature drift X,Y	$\Delta X/\Delta T; \Delta Y/\Delta T$ typ. 0,2 digits/°C (< 0,01% / °C)	
Color difference	$\Delta E \geq 0,5$	
Color space	X Y INT siM (Lab)	
Color memory capacity	non-volatile EEPROM with parameter sets for max. 31 colors	
Housing dimensions	length approx. 130 mm x Ø 32 mm (threaded M34x1.5) or Ø 34 mm (optics holding device), without connectors	
Housing material	aluminum, anodized in blue (optics holding device: aluminum, anodized)	
Enclosure rating	IP67 (optics), IP64 (electronics)	
Connecting cables	to PLC: cab-las8/SPS or cab-las8/SPS-w to PC/RS232 interface: cab-las4/PC or cab-las4/PC-w to PC/USB interface: cab-las4/USB or cab-las4/USB-w to PC/Ethernet interface: SI-RS232/Ethernet-4	
Type of connector	connection to PLC: 8-pole fem. connector (Binder 712), connection to PC: 4-pole fem. connector (Binder 707)	
Operating temp. range	-20°C ... +55°C	
Storage temperature range	-20°C ... +85°C	
EMC test acc. to	DIN EN 60947-5-2	



Dimensions

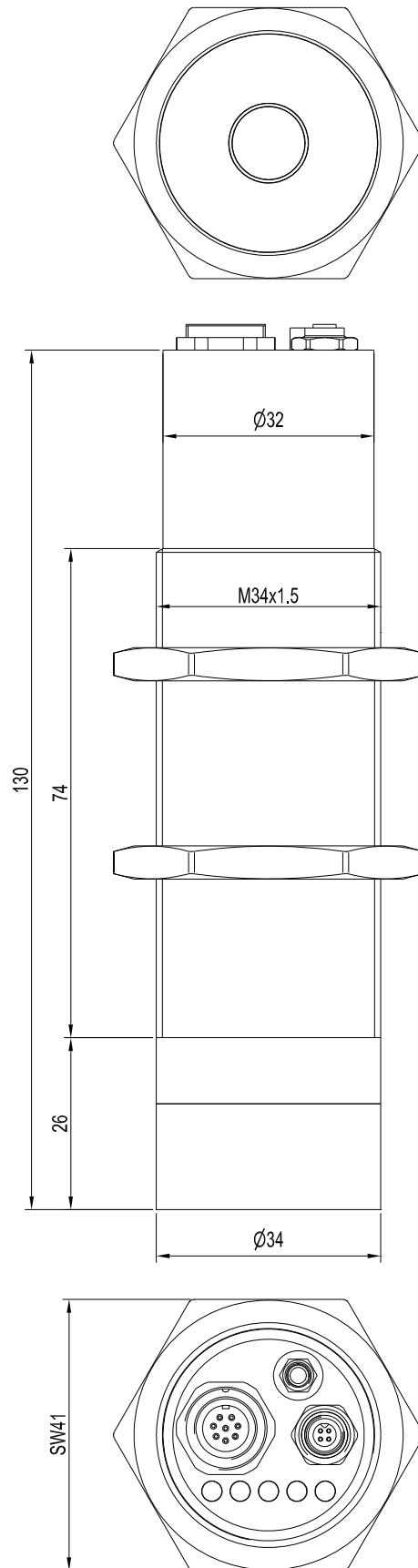

All dimensions in mm



Connector Assignment

**Connection to PLC:**  
8-pole fem. connector Binder Series 712

Pin:	Color:	Assignment:
1	white	GND (0V)
2	brown	+24VDC ( $\pm 10\%$ )
3	green	IN0
4	yellow	OUT0 (Digital 0: typ. 0...1V, Digital 1: typ. +Ub - 10%)
5	grey	OUT1 (Digital 0: typ. 0...1V, Digital 1: typ. +Ub - 10%)
6	pink	OUT2 (Digital 0: typ. 0...1V, Digital 1: typ. +Ub - 10%)
7	blue	OUT3 (Digital 0: typ. 0...1V, Digital 1: typ. +Ub - 10%)
8	red	OUT4 (Digital 0: typ. 0...1V, Digital 1: typ. +Ub - 10%)

Connecting cable:  
cab-las8/SPS-(length)  
cab-las8/SPS-w-(length) (angle type, 90°)  
(standard length 2m)

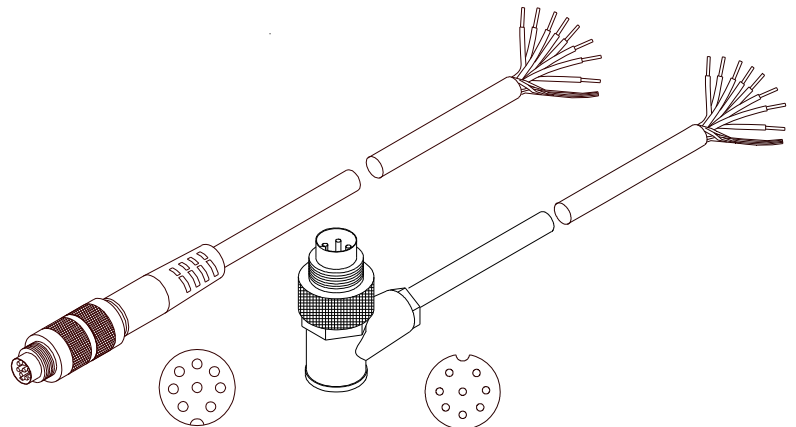

cab-las8/SPS-... (max. length 25m, outer jacket: PUR)      cab-las8/SPS-w-... (max. length 25m, outer jacket: PUR)

**Connection to PC:**  
4-pole fem. connector Binder Series 707

Pin:	Assignment:
1	+24VDC (+Ub, OUT)
2	GND (0V)
3	RxD
4	TxD

**Connection via RS232 interface at the PC:**  
Connecting cable:  
cab-las4/PC-(length)  
cab-las4/PC-w-(length) (angle type 90°)  
(standard length 2m)

**alternative:**  
**Connection via USB interface at the PC:**  
Connecting cable (incl. driver software):  
cab-las4/USB-(length)  
cab-las4/USB-w-(length) (angle type 90°)  
(standard length 2m)

**alternative:**  
**Connection to local network via Ethernet bus:**  
Adapter (based on Lantronix XPortModul):  
SI-RS232/Ethernet-4-(length)  
(standard length 2m)

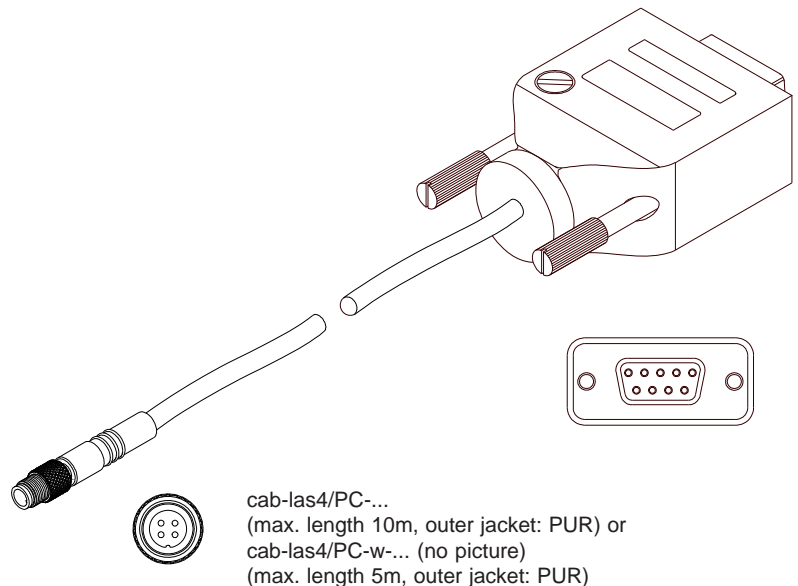

cab-las4/PC-... (max. length 10m, outer jacket: PUR) or  
cab-las4/PC-w-... (no picture)  
(max. length 5m, outer jacket: PUR)

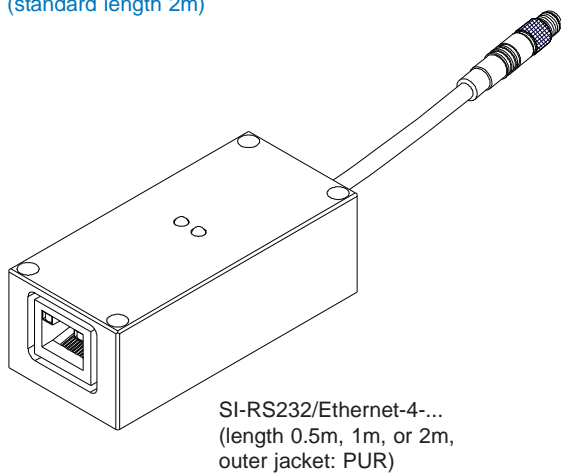

SI-RS232/Ethernet-4-...  
(length 0.5m, 1m, or 2m,  
outer jacket: PUR)

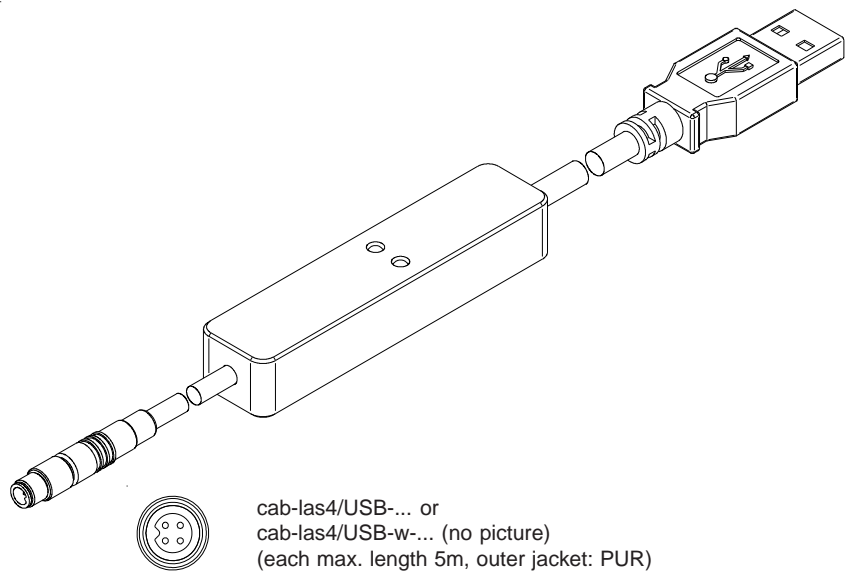

cab-las4/USB-... or  
cab-las4/USB-w-... (no picture)  
(each max. length 5m, outer jacket: PUR)



## Measuring Principle

### Measuring principle of color sensors of SPECTRO-3-...-UV series:

The SPECTRO-3 provides highly flexible signal acquisition. For example, the sensor can be operated in alternating-light mode (AC mode), which makes the sensor insensitive to extraneous light. It also can be set to constant-light mode (DC mode), which makes the sensor extremely fast and allows a scan-frequency of up to 35 kHz.

When the integrated light source of the SPECTRO-3-...-UV color sensor is activated, the sensor detects the radiation that is diffusely reflected from the object to be measured.

As a light source the SPECTRO-3-...-UV color sensor uses a UV-LED (375 nm, or 365 nm in case of using an external UV illumination unit SPECTRO-ELS-UV) with adjustable transmitter power to excite the luminescent marking. An integrated 3-fold receiver for the red, green, and blue content of the visible light that is emitted by the luminescent marking is used as a receiver. A special feature here is that the gain of the receiver can be set in 8 steps. This makes it possible to optimally adjust the sensor to almost any luminescent colorant that can be excited in the long-wave UV range (375 nm or 365 nm).

The SPECTRO-3 color sensor can be "taught" up to 31 colors. For each of these taught colors it is possible to set tolerances. In X/Y INT or s/i M mode these tolerances form a color cylinder in space. In X/Y/INT or s/i/M mode the tolerances form a color sphere in space. Color evaluation according to s/i M is based on the lab calculation method. All modes can be used in combination with several operating modes such as "FIRST HIT" and "BEST HIT". Raw data are represented with 12 bit resolution.

As a special feature the sensor can be taught two completely independent parameter sets. Input IN0 can then be used to tell the sensor which parameter set it should work with.

Color detection either operates continuously or is started through an external PLC trigger signal. The respective detected color either is provided as a binary code at the 5 digital outputs or can be sent directly to the outputs, if only up to 5 colors are to be detected. At the same time the detected color code is visualised by means of 5 LEDs at the housing of the SPECTRO-3. [Please note: Visualisation by means of LEDs not available with SPECTRO-3-...-JR types.]

With a TEACH button at the sensor housing the color sensor can be taught up to 31 colors. For this purpose the corresponding evaluation mode must be set with the software. The TEACH button is connected in parallel to the input IN0 (green wire at cable cab-las8/SPS). [Please note: TEACH button not available with SPECTRO-3-...-JR types.]

Parameters and measurement values can be exchanged between a PC and the SPECTRO-3 color sensor through the serial RS232 interface. All the parameters for color detection also can be saved to the non-volatile EEPROM of the SPECTRO-3 color sensor through this serial RS232 interface. When parameterisation is finished, the color sensor continues to operate with the current parameters in STAND-ALONE mode without a PC.

The sensors of the SPECTRO-3-...-UV series also can be calibrated. Analogous to white-light balancing with color sensors, balancing of the SPECTRO-3-...-UV could be performed to any luminescent color marking.



## Visualization

### Visualization of the color code:

The color code is visualised by way of 5 yellow LEDs at the housing of the SPECTRO-3 color sensor. At the same time in the binary mode (OUT BINARY) the color code indicated on the LED display is output as 5-bit binary information at the digital outputs OUT0 to OUT4 of the 8-pin SPECTRO-3/PLC socket.

The SPECTRO-3 color sensor is able to process a maximum of 31 colors (color code 0 ... 30) in accordance with the corresponding rows in the COLOR TEACH TABLE. An "error" respectively a "not detected color" is displayed by the lighting of all LED (OUT0 ... OUT4 digital outputs are set to HIGH-level).

In the DIRECT mode (OUT DIRECT HI or OUT DIRECT LO) the maximum numbers of colors to be taught is 5 (color no. 0, 1, 2, 3, 4). If DIRECT HI is activated, the specially digital output is set to HI, while the other 4 are set to LO. If the current color does not correspond with any of the teach-in colors, all digital outputs are set to LOW (no LED is lighting).

If DIRECT LO is activated, the specially digital output is set to LO, while the other 4 are set to HI. If the current color does not correspond with any of the teach-in colors, all digital outputs are set to HIGH (all LED are lighting).



LED Display

**LED display:**

The color code is visualized by means of 5 yellow LEDs at the housing of the color sensor. At the same time the color code indicated at the LED display is output as 5-bit binary information at the digital outputs OUT0 ... OUT4 of the 8-pole PLC connector.

In the DIRECT mode the maximum number of color codes to be taught is 5. These 5 color codes can be directly output at the 5 digital outputs. The respective detected color code is displayed by means of the 5 yellow LEDs at the color sensor housing.

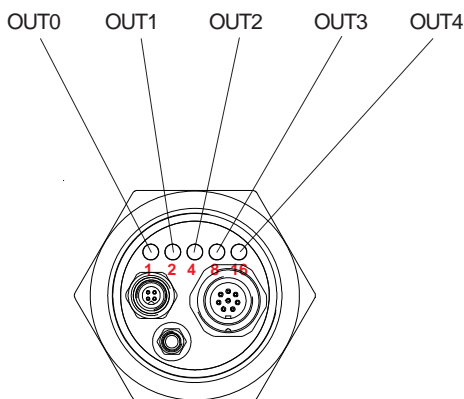
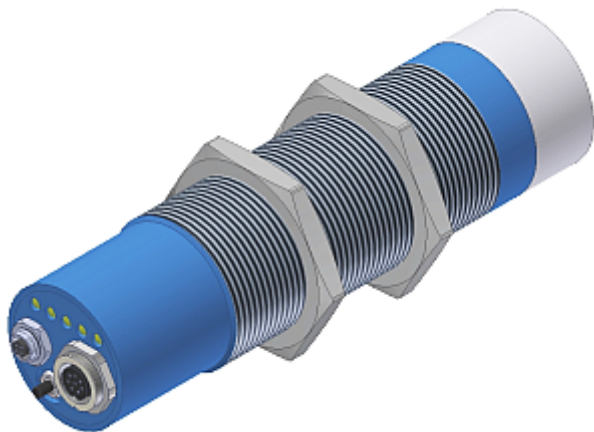

○ ○ ○ ○ ○ 0	● ○ ○ ○ ○ 1	○ ● ○ ○ ○ 2
● ● ○ ○ ○ 3	○ ○ ● ○ ○ 4	● ○ ● ○ ○ 5
○ ● ● ○ ○ 6	● ● ● ○ ○ 7	○ ○ ○ ● ○ 8
● ○ ○ ● ○ 9	○ ● ○ ● ○ 10	● ● ○ ● ○ 11
○ ○ ● ● ○ 12	● ○ ● ● ○ 13	○ ● ● ● ○ 14
● ● ● ● ○ 15	○ ○ ○ ○ ● 16	● ○ ○ ○ ● 17
○ ● ○ ○ ● 18	● ● ○ ○ ● 19	○ ○ ● ○ ● 20
● ○ ● ○ ● 21	○ ● ● ○ ● 22	● ● ● ○ ● 23
○ ○ ○ ● ● 24	● ○ ○ ● ● 25	○ ● ○ ● ● 26
● ● ○ ● ● 27	○ ○ ● ● ● 28	● ○ ● ● ● 29
○ ● ● ● ● 30	● ● ● ● ● Error or „not detected“	

**Parameterization**
**Windows® user interface:**

The color sensor is parameterized under Windows® with the SPECTRO3-Scope software. The Windows® user interface facilitates the teach-in process at the color sensor and supports the operator in the task of adjustment and commissioning of the color sensor.

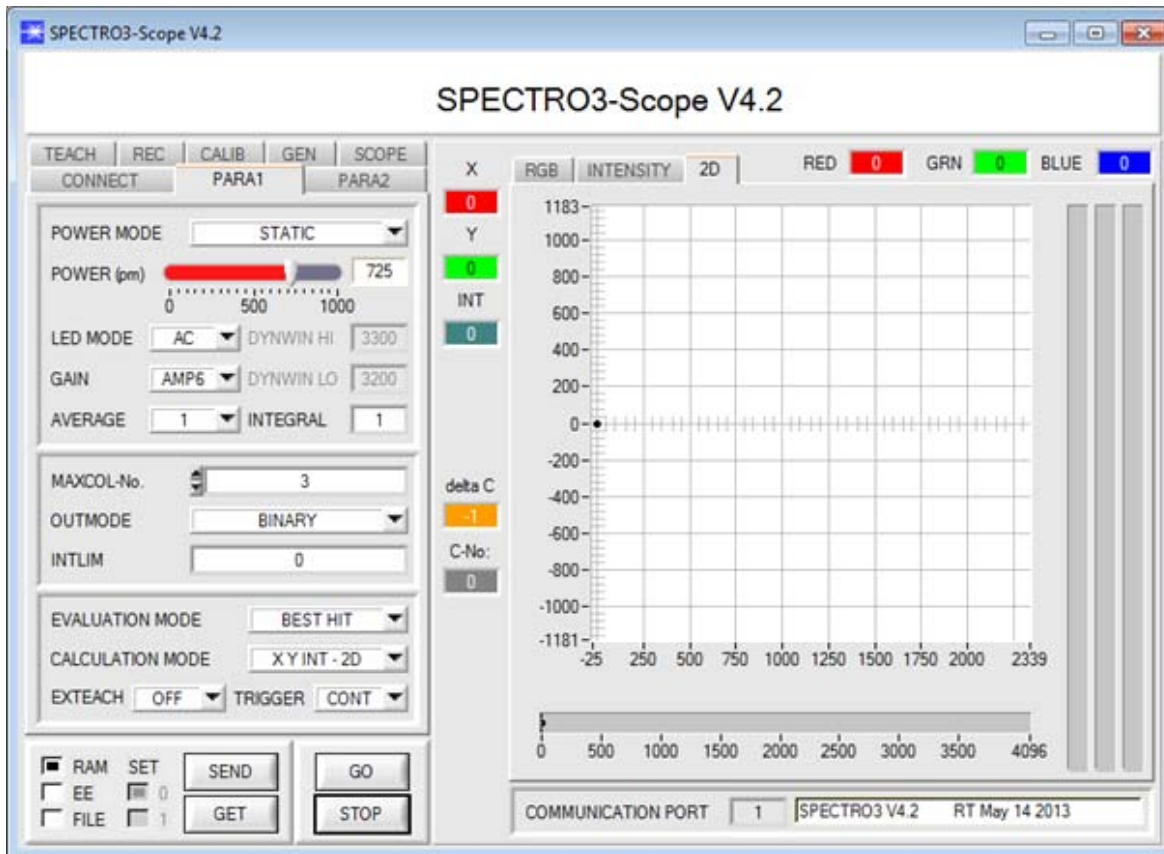

Under Windows® representation of the color value on a PC in numeric form and in a color chart, and representation of RGB values in a time chart. In addition the current RGB values are displayed as a bar chart.

The RS232 interface (tab PARA1 or PARA2) is used for setting parameters such as:

- POWER MODE: Light power of the LED
- LED MODE: Triggering of the internal light source
- GAIN: Used for setting the gain of the receiver
- AVERAGE: Averaging over a maximum of 32768 values
- INTEGRAL: This function field is used to set the number of scan values (measurement values) over which the raw signal measured at the receiver is summed up. This integral function allows the reliable detection even of extremely weak signals
- MAXCOL-No.: Number of colors to be checked
- OUTMODE: Triggering of the digital outputs
- INTLIM: Minimum intensity required for color evaluation
- EVALUATION MODE: Various evaluation modes to choose from (FIRST HIT, BEST HIT, MIN DIST, COL5, THD RGB)
- CALCULATION MODE: There are 2 methods of teaching a color, which are selectable via CALCULATION MODE. The CALCULATION MODE „X Y INT - 3D“ (or „s i M - 3D“) uses a color sphere in space with radius TOL. Contrary to this, the CALCULATION MODE „X Y INT - 2D“ (or „s i M - 2D“) uses a color cylinder in space with radius CTO or siTO and with height ITO or M. The teach process is the same for both methods. Color evaluation according to "s i M - 2D" uses the Lab calculation method
- EXTEACH: In all the evaluation modes teaching of a color can be performed externally through IN0 or by means of the button at the sensor housing [Please note: TEACH button not available with SPECTRO-3-...-JR types.]
- TRIGGER: Continuous or external or self trigger



## Firmware Update

### Firmware update by means of software „ProgramLoader“ or „FirmwareLoader“:

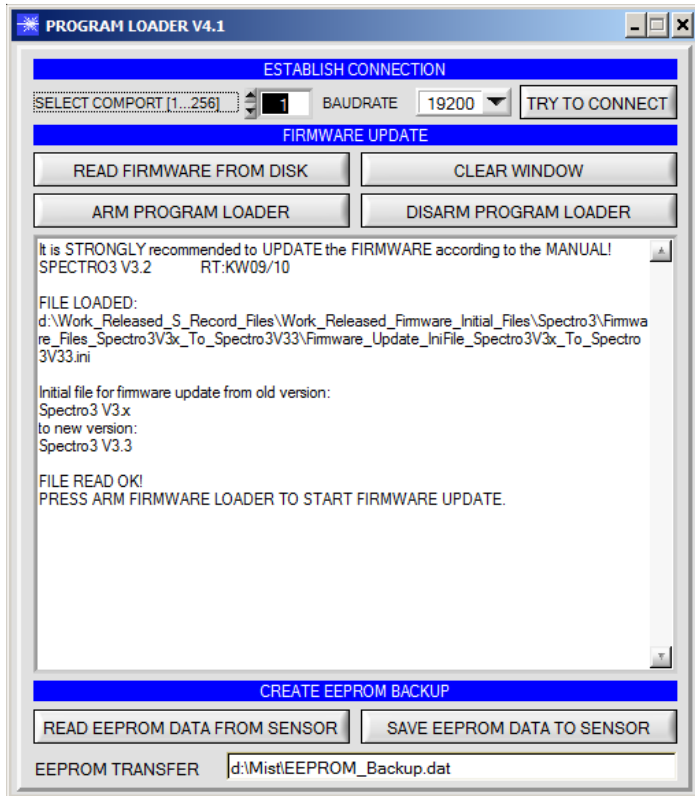

The software „ProgramLoader“ or „FirmwareLoader“ allows the user to perform an automatic firmware update. The update will be carried out through the RS232 interface.

An initialisation file (xxx.ini) and a firmware file (xxx.elf.S) are required for performing a firmware update. These files can be obtained from your supplier. In some cases an additional firmware file for the program memory (xxx.elf.p.S) is also needed, and this file will be automatically provided together with the other two files.

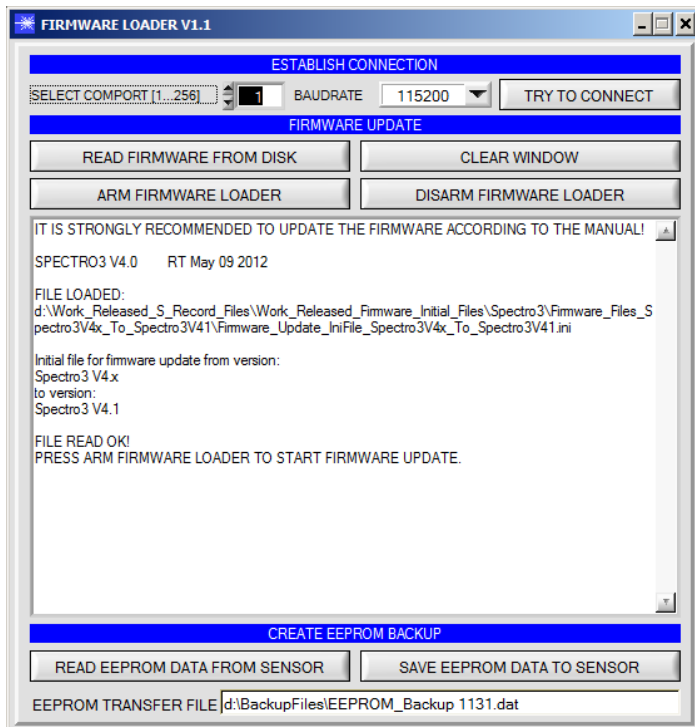



Mounting Accessories

**FL-34**  
(flange)

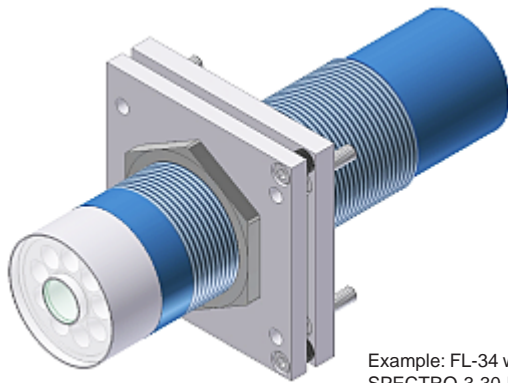
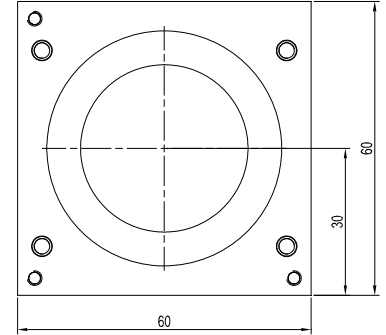
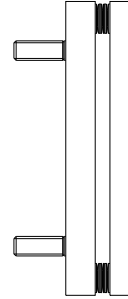
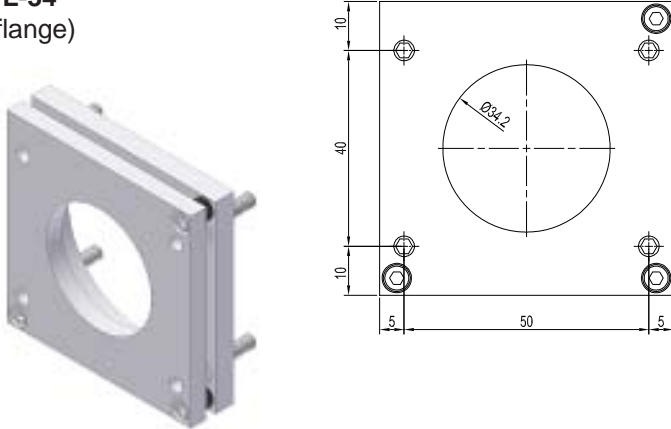

Example: FL-34 with  
SPECTRO-3-30-DIL  
mounted

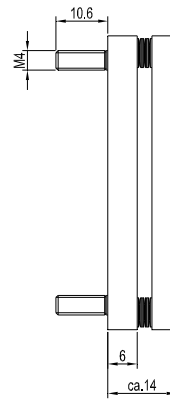

**WFL-34**  
(flange, angle type 90°)

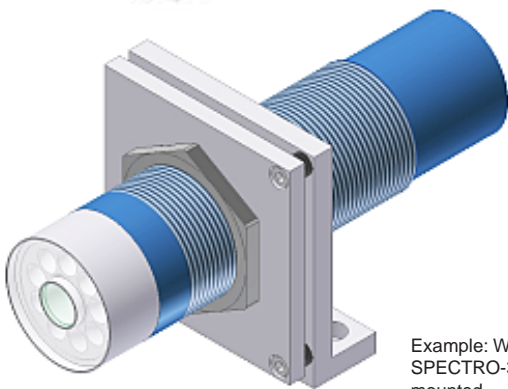
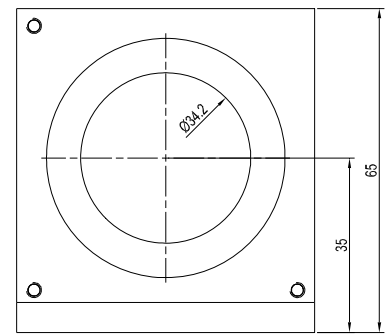
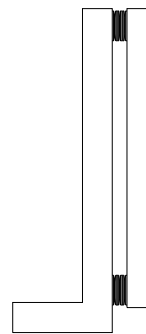

Example: WFL-34 with  
SPECTRO-3-30-DIL  
mounted

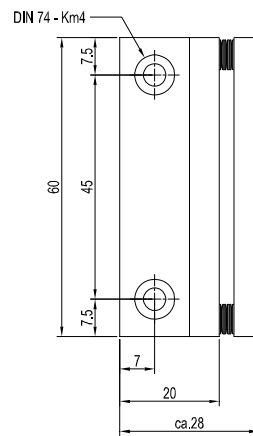

(All dimensions in mm)



Accessories

**SPECTRO-3-30-OFL**  
**offline top part/spacer**  
 (please order separately)

The spacer is mounted onto the optics of the SPECTRO-3-30-UV, thus the color sensor can be used as a hand-held unit.

For the purpose of color control the SPECTRO-3-30-UV with the spacer is put directly on the surface to be checked.

By means of the spacer directly put on the surface, the color sensor SPECTRO-3-30-UV works at a reference distance of 30 mm to the measuring object.



SPECTRO-3-30-UV  
 with offline top part SPECTRO-3-30-OFL

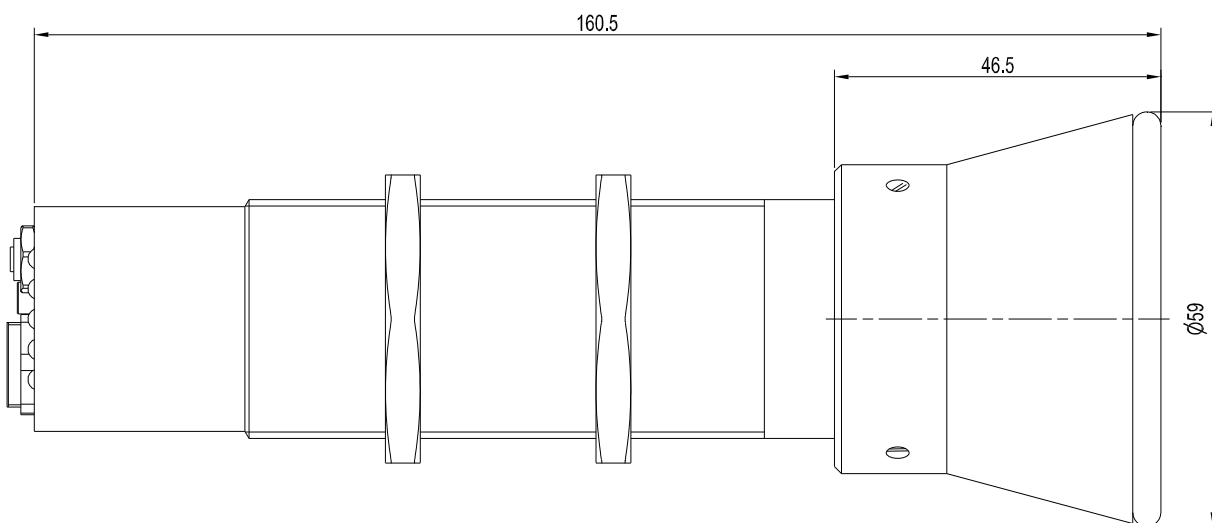
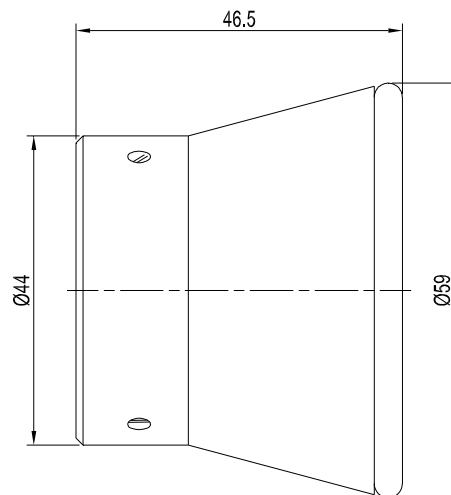
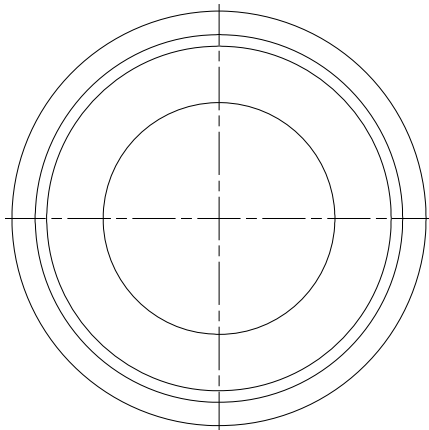

All dimensions in mm